

WRS
MODEL

**COUNTER BALANCE
REACH STACKER**

**CAPACITY
1.2-1.5 ton**

**LIFTING HEIGHT
2,500-4,500 mm.**

Model

**WRS12-810
WRS15-810**



WRS-12/15-810

 **DRAWINGS FOR
SPECIFICATIONS**

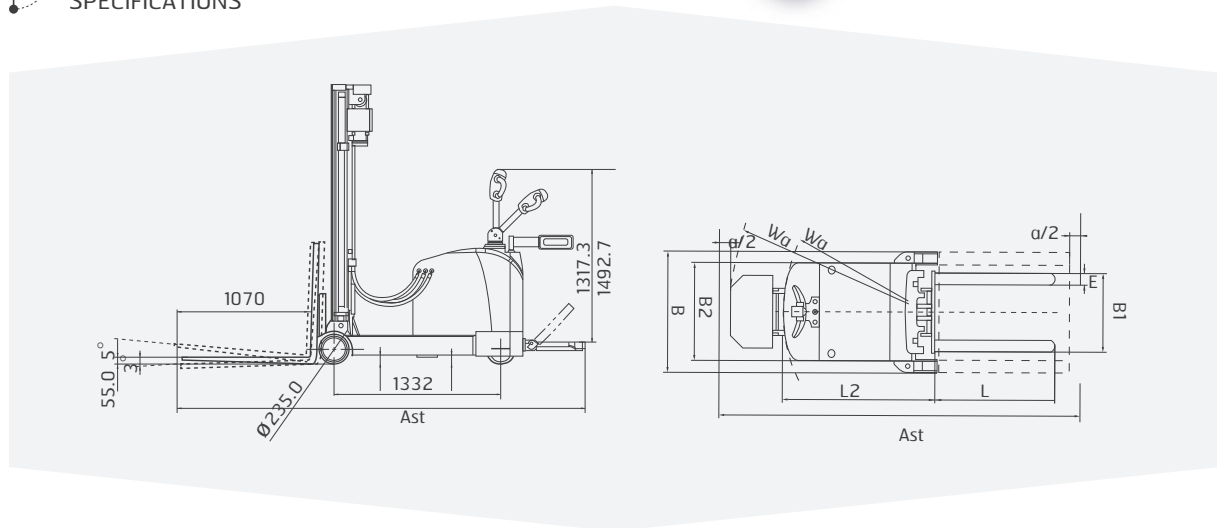

SPECIFICATIONS

MODEL			WRS12/15-810	WRS12/15-810
Feature	Type		Reach	Reach
	Mast type		2-Stage STD	Full Free 3-Stage
	Load capacity	kg	1200/1500	1200/1500
	Load center	mm	500	500
	Wheel base	mm	1332	1332
	Operating type		Stand on	Stand on
Wheels	Wheels type		PU	PU
	Wheel quantity Driving wheel / Balance wheel / Bearing wheel		1/0/2	1/0/2
Dimension	Reach distance	mm	0-425	0-425
	Standard lift height	mm	1400/2000/2500/3000/ 3300/3600/4000	3700/3900/4200/4500/5000
	Max. extend height	mm	2235/2835/3335/3835/ 4135/4435/4835	4580/4780/5080/5380/5880
	Mast lowered height	mm	1490/1790/2040/2290/ 2440/2590/2790	1832/1898/1998/2098/2350
	Lowered fork height	mm	55	55
	Fork size (length / width / thickness)	mm	1070/100/40	1070/100/40
	Overall length	mm	2440/2896	2440/2896
	Overall width	mm	1083	1083
	B1 Outside width between forks	mm	200-755	200-755
	Tilt of fork (Forward / Backward)	%	3/5	3/5
	Wa Min. turning radius	mm	1596/2040	1596/2040
	Ast Min. Aisle width for pallets 800x1200	mm	3023/3456	3023/3456
	Ast Min. Aisle width for pallets 1200x1200	mm	3044/3472	3044/3472
	Min. ground clearance	mm	60	60
Performance	Travel speed (laden/unladen)	km/h	5/5.5	5/5.5
	Lift speed (laden/unladen)	mm/s	130/230	130/230
	Lowering speed (laden/unladen)	mm/s	130/230	130/230
	Gradeability (laden/unladen)	%	3/5	3/5
Electrical configuration	Drive motor / Lift motor / Steering motor	KW	AC1.5 / DC3.0 / DC0.15	AC1.5 / DC3.0 / DC0.15
	Battery voltage	V	24	24
	Battery capacity	Ah	280	280
	Brake		Electromagnetic / Regenerative	Electromagnetic / Regenerative
	Controller		Curtis	Curtis
Weight	Battery weight	kg	235	235
	Service weight battery	kg	2100	2300

*The Specification is subject to change without prior notice.