

**STK
MODEL**

**MANUAL
STACKER**



**CAPACITY
500-1,500 KG**



**FORK HEIGHT
1,600-2,500 mm.**



STK1016

**DRAWINGS FOR
SPECIFICATIONS**

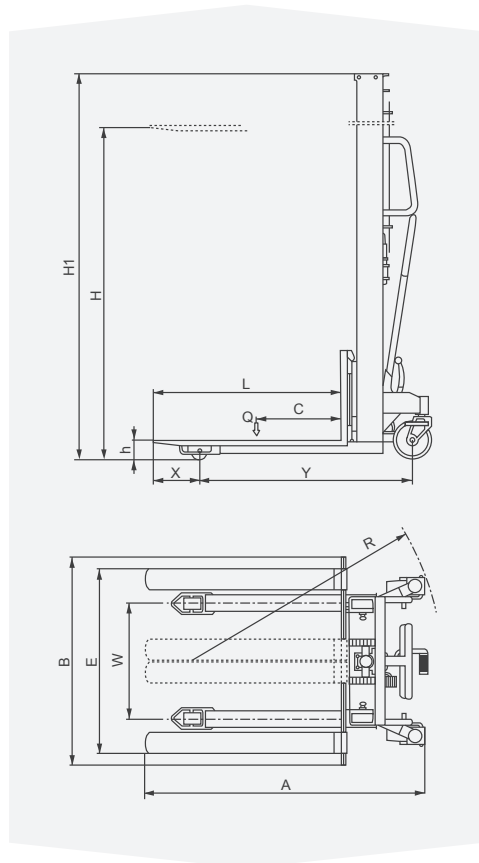

- Robust steel profile construction
- An economical left to handle task from transporting dies and moulds skids and pallets
- Sturdy and compact enough to fit through standard door and to operate in congested areas

SPECIFICATIONS

		STK0516	STK1016	STK1025	STK1516	
Capacity	Q	500	1000	1000	1500	kg
Load Center	C	400	500	500	500	mm
Max. Fork Height	H	1600	1600	2500	1600	mm
Fork Length	L	1000	1000	1000	1000	mm
Fork Width	E	210-800	295-930	295-930	295-930	mm
Min. Turning Radius	R	1110	1235	1235	1235	mm
Wheel Base	Y	996	1100	1100	1100	mm
Front-Wheel Distance	X	213	350	350	350	mm
Overall Length	A	1280	1680	1680	1680	mm
Overall Width	B	800	955	955	955	mm
Overall Height	H1	1980	2070	1850	2070	mm
Overall Net Weight		155	240	306	245	kg

*The Specification is subject to change without prior notice.