

**SLT
MODEL**

**MANUAL SCISSOR
LIFT TABLE**



**CAPACITY
150-1,500 KG**



**LIFTING HEIGHT
740-1,500 mm.**



**DRAWINGS FOR
SPECIFICATIONS**

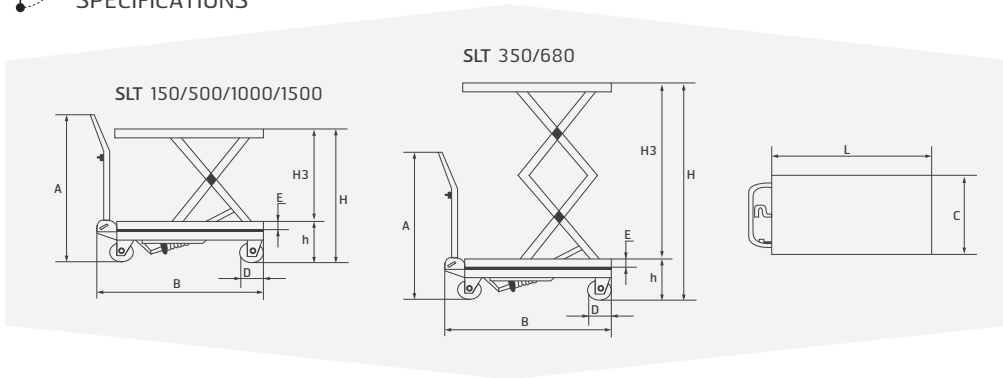

SPECIFICATIONS

		SLT150	SLT350	SLT500	SLT680	SLT1000	SLT1500	
Capacity		150	350	500	680	1000	1500	kg
Max. Lift Height	H	740	1300	900	1500	1000	1000	mm
Min. Height Of Table	h	225	350	280	474	380	420	mm
Lifting Height	H3	515	950	620	1026	620	580	mm
Table Size	L x C x E	700x450x35	910x500x52	815x500x50	1220x610x55	1016x515x60	1220x610x60	mm
Total Height	A	935	970	996	1038	962	962	mm
Overall Length	B	770	980	942	1289	1170	1379	mm
Foot Pedal Cycles To Max. Height		< 25	< 60	< 45	< 80	< 55	< 70	
Wheel Diameter	D	100	127	127	150	150	150	mm
Weight		42	110	85	170	115	135	kg

*The Specification is subject to change without prior notice.