

**HPT
MODEL**

**HIGH LIFT
PALLET TRUCK**

**1.0
1.5** ton

HIGHER LIFTING
TO SUPPORT EXTRA CONDITION.



HPT103



HPT101 / 152

 **DRAWINGS FOR
SPECIFICATIONS**

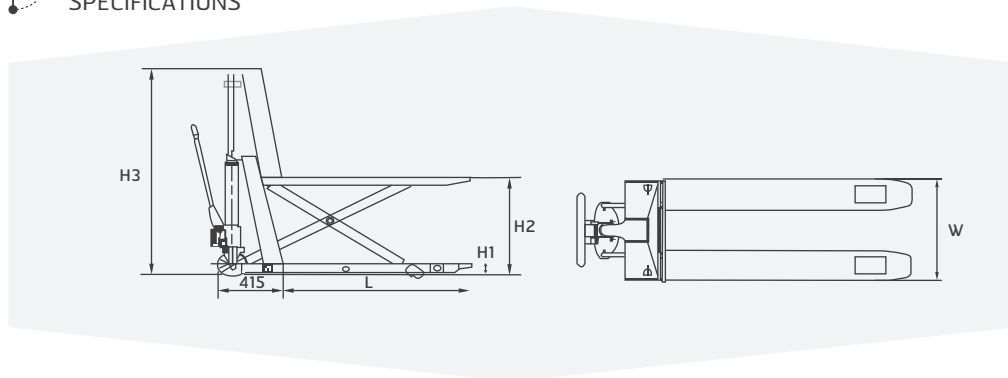

SPECIFICATIONS

		HPT101	HPT103	HPT152	
Capacity		1000	1000	1500	kg
Total Lift Height	H2	800	800	800	mm
Lowered Fork Height	H1	85	85	85	mm
Total Height	H3	1210	1225	1225	mm
Fork Length	L	1220	1150	1100	mm
Width Over The Forks	W	685	520/685	680	mm
Steering Wheel		Φ 180 x 50	Φ 180 x 50	Φ 180 x 50	mm
Fork Wheel		Φ 74 x 50	Φ 74 x 50	Φ 78 x 60	mm
Truck Weight		112	112	135	kg

*The Specification is subject to change without prior notice.