

**PTU
MODEL**

**HAND PALLET
TRUCK**

2.5
3.0 ton

REINFORCED FOR
ADDED STRENGTH OF
LOAD CAPACITY.



PTU256 / PTU306



- A. Oil Greasing
- B. Solid Tappet

**DRAWINGS FOR
SPECIFICATIONS**

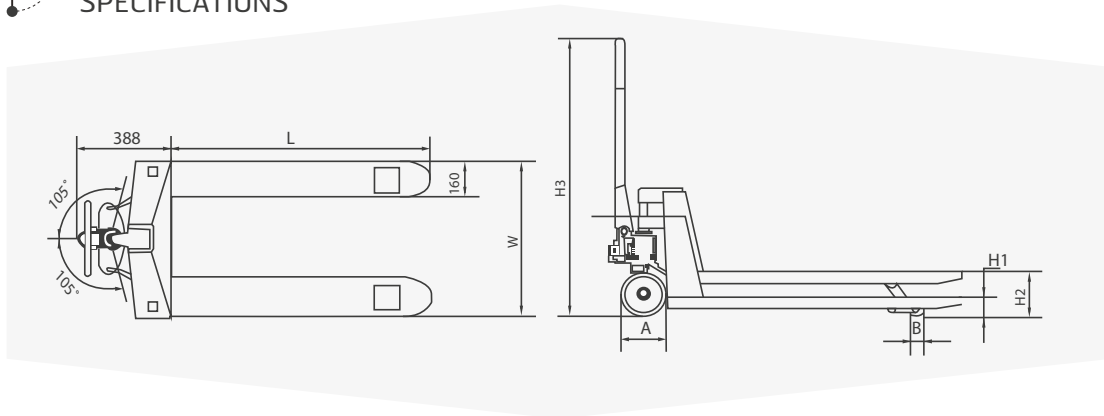

5.0 ton

REINFORCED FOR
ADDED STRENGTH OF
LOAD CAPACITY.



PTU506



ROBUS DESIGN FOR ALL PURPOSES



SPECIFICATIONS

		PTU255	PTU256	PTU305	PTU306	PTU505	PTU506	
Capacity		2500	2500	3000	3000	5000	5000	kg
Max. lift height	H1	195	195	195	195	205	205	mm
Lowered fork height	H2	85	85	85	85	85	85	mm
Total height	H3	1224	1224	1224	1224	1253	1253	mm
Fork length	L	1150	1220	1150	1220	1150	1220	mm
Width over the forks	W	520	685	520	685	550	685	mm
Steering wheel	A	Φ 200	Φ 200	Φ 200	Φ 200	Φ 200	Φ 200	mm
Fork wheel	B	Φ 80x70	Φ 80x70	Φ 80x70	Φ 80x70	Φ 85x80	Φ 85x80	mm
Truck weight		75	75	75	75	103	103	kg

*The Specification is subject to change without prior notice.